

## DC Motor Control

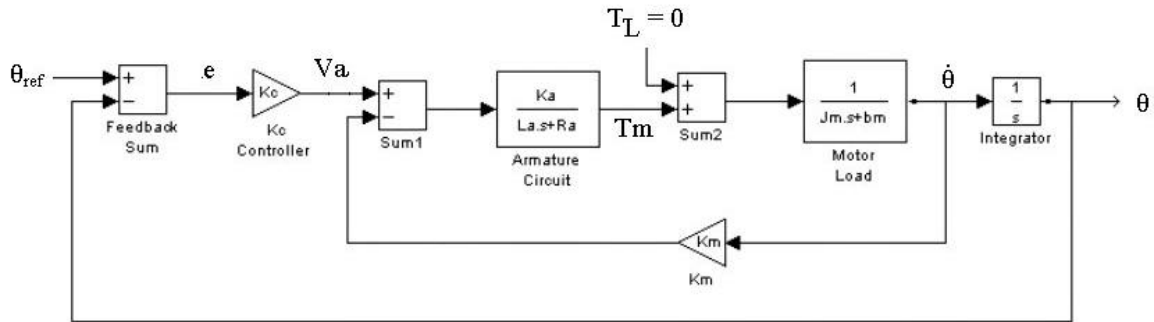

$K_a = 6e-5$        $K_m = 5.5e-2$        $K_c = 5.3542$        $R_a = 0.2$        $J_m = 5.4e-5$        $b_m = 4.0e-4$

$$\frac{\theta}{V_a} = \frac{K_a}{(s)(L_a J_m s^2 + (R_a J_m + b_m L_a)s + (R_a b_m + K_m K_a))}$$

- 1) Derive the plant transfer function  $\theta/V_a$ , and the closed loop transfer functions  $\theta/\theta_{ref}$ ,  $V_a/\theta_{ref}$  and  $T_m/\theta_{ref}$  and include these derivations in the report.

Hint: To find the  $T_m/\theta_{ref}$  transfer function find the  $T_m/V_a$  and  $V_a/\theta_{ref}$  transfer functions.

- 2) On one graph plot the poles of the  $\theta/\theta_{ref}$  transfer function as  $L_a$  varies over the following values,  $L_a = [0,0.1,0.2,0.3,0.4,0.5,0.6,0.7,0.8]$ . Be sure to label these points in MATLAB. Hint: You can adapt the following MATLAB code for use in your script file to label the poles.

```
rpmstring = ['La = ' num2str(La)];
gtext(rpmstring)
```

**Get this graph initialed by the TA and turn in as part of your lab report.**

**Question:** How do the poles of  $\theta/\theta_{ref}$  move in the s-plane as  $L_a$  varies?

**Question:** When  $L_a = 0$  where are the three poles of our system? Alternatively, where did the third pole go? (Hint: What happens as  $L_a$  got big? Looking at the reverse situation, as  $L_a$  gets smaller where does the third pole go?)

- 3) Create the open loop frequency response, KP, for  $L_a = [0,0.1,0.2,0.3]$ . Plot the magnitude responses on one graph and the phase response on another. Use either *subplot* command or create graphs on separate pages (one page for magnitude and one for phase). The magnitude must be expressed in decibels and the phase in degrees. Use the *gtext* or *text* command to label your plots with the corresponding  $L_a$  values.

**Get this graph initialed by the TA and turn in as part of your lab report.**

- 4) Create the sensitivity frequency response for  $L_a = [0,0.1,0.2,0.3]$ . Plot the magnitude responses on one graph and the phase responses on another graph. Use either the *subplot* command or create graphs on separate pages (one page for magnitude and another for phase). The magnitude must be expressed in decibels and the phase in degrees. Use the *gtext* or *text* command to label your plots.

**Get this graph initialed by the TA and turn in as part of your lab report.**

**Derive the expression for the sensitivity and include this as part of your report.**

- 5) Create the complementary sensitivity frequency response for  $L_a = [0,0.1,0.2,0.3]$ . Plot the magnitude responses on one graph and the phase responses on another graph. Use either the *subplot* command or create graphs on separate pages (one for magnitude and another for phase). The magnitude must be expressed in decibels and the phase in degrees. Use the *gtext* or *text* command to label your plots.

**Get this graph initialed by the TA and turn in as part of your lab report.**

**Derive the expression for the complementary sensitivity and include this as part of your report.**

- 6) Create a graph of the step response using  $L_a = [0.001,0.101,0.201,0.301]$  for the output, input motor voltage, torque and tracking error. Label each graph with the input signal (step) and output signal (ex. output, voltage, tracking error, or torque). Label your axes.

i) Output,  $y$ , on one graph as  $L_a$  varies.

**Get this graph initialed by the TA and turn in as part of your lab report.**

**Question: How does the output behave as  $L_a$  increases? Why?**

ii) Input Motor Voltage,  $V_a$ , on one graph as  $L_a$  varies.

**Get this graph initialed by the TA and turn in as part of your lab report.**

iii) Torque,  $T$ , on one graph as  $L_a$  varies.

**Get this graph initialed by the TA and turn in as part of your lab report.**

iv) Tracking error,  $e$ , on one graph as  $L_a$  varies.

**Get this graph initialed by the TA and turn in as part of your lab report.**

- 7) Create a graph of the ramp response using  $L_a = [0.001,0.101,0.201,0.301]$  for the output, input motor voltage, torque and tracking error. Label each graph with the input signal (ramp) and output signal (ex. output, voltage, tracking error, or torque). Label your axes.

i) Output,  $y$ , on one graph as  $L_a$  varies.

**Get this graph initialed by the TA and turn in as part of your lab report.**

ii) Input motor voltage,  $V_a$ , on one graph as  $L_a$  varies.

**Get this graph initialed by the TA and turn in as part of your lab report.**

iii) Torque,  $T$ , on one graph as  $L_a$  varies.

**Get this graph initialed by the TA and turn in as part of your lab report.**

iv) Tracking Error,  $e$ , on one graph as  $L_a$  varies.

**Get this graph initialed by the TA and turn in as part of your lab report.**